



INBJUDAN EMC DESIGN SEMINARIUM

Arrangeras av
DELTA och Würth Elektronik

18 November i Västerås, Sweden

Hur designar man en säker kvalitetsprodukt

DELTA Presentation på Svenska:

Nyheter och trender inom EMC standardisering (Ulf Bjerke)

Nya EMC direktivet i kraft. Test mot högre frekvenser (Emission/Immunitet), Alternativa testmetoder. Medicinska maskiner måste uppfylla delar av maskindirektivet enligt det nya Medical Device Directive 2004/47/EC article 3.

Focus on EMC in safety related products – EMC issues in safety assessments (Kristan B. Voetmann) Presentation will be in English

The legal EMC requirements in EU are specified in the EMC directive and in EU directives focusing on safety of equipment. Directives are made to protect different interests. DELTA informs about the directives main focuses, and about, which influence this can have on EMC in products.

Säkerhetsaspekter i en trådlös produkt (Fredrik Thorsell)

DELTA informerar om de säkerhetsaspekter man ska uppmärksamma när man designar en säker radioprodukt, och hur man kan testa om radiodelen av produkten är säker.

Säker EMC design (Ulf Bjurman)

DELTA presenterar vilka de vanligaste design felet i en konstruktion är, och hur man undviker dem.

EMC demo: Praktiska Pcb råd (Fredrik Thorsell)

En praktisk demonstration av EMC problem på kretskorts nivå.

Würth Elektronik eiSos presentation in English:

Würth Elektronik will present the basics knowledge of EMC ferrites and inductors: Starting with basic principles, foundations of inductive components and simulation models. This leads into an comprehensive overview of basic principles of optimized EMI filter designs of numerous industrial applications, live measurement, selection of Products and simulation with LTSpice.



EMC Seminarium 14 nov.

08.30 Registrering och fika

09.00 Välkomna till seminariet

- 09.05 Nyheter om EMC direktivet och standarder (Ulf Bjerke)
- 09.30 Focus on EMC in safety related products (Kristian B. Voetmann)

10.35 Paus med Fika

- 10.45 Säkerhetsaspekter i en trådlös produkt (Fredrik Thorsell)
- ~~11.00 Säker EMC design (Ulf Bjurman)~~
- 11.30 EMC demo: Praktiska PCB råd (Fredrik Thorsell)

12.00 Lunch

- 13.00 Würth 1 (Lorandt Fölkel)

14.30 Paus

- 14.45 Würth 2 (Lorandt Fölkel)

16.00 Avslutning



We help ideas meet the real world



EMC – Functional safety

New Work Item proposal on IEC 61000-6-7:

Generic standards - Immunity requirements for safety-related systems and for equipment intended to perform safety-related functions (functional safety) in industrial environments

Purpose and justification

The immunity requirements in IEC 61000-6-2 have been selected to ensure an adequate level of immunity for equipment used in non-safety-related applications, but the required immunity levels do not cover extreme cases that may occur at any location but with an extremely low probability of occurrence.

Table 9 – Applicable performance criteria and observed behaviour during test for equipment intended for use in safety-related systems

Specified function			
Function intended for safety application		Function not intended for safety application	
Normal EMC test levels	EMC safety test levels	Normal EMC test levels	EMC safety test levels
Performance criteria according to the relevant product standard <ul style="list-style-type: none">- A, or- B + observed deviation + recovery time to be documented, or- C + observed behaviour, detectable and documented	Performance criteria FS	Performance criteria according to the relevant product standard <ul style="list-style-type: none">- A, or- B, or- C	May fail

NOTE 1 The description of the performance criteria A, B and C is given in the generic standard IEC 61000-6-2 or relevant product standards such as IEC 61326-1.

Performance criteria B:

(transienta störningar)

Får störas men ska återgå till normal funktion när störningen försvinner.

Kan vara OK om en bormaskin tillfälligt stannar men inte bra för en helikopter



Standard uppdatering

Nov 2009



Standard nytt

- Övergångstiden för "Nya" EMC direktivet utgick juli 2009
- Emissionskrav över 1 GHz kommer i flera standarder
- Alternativa mätmetoder.
- CISPR 16 bas standard för mätmetoder.
- Kommande standard för Multimedia utrustning.
- mm



"Nya" EMC direktivet 2004/108/EC

- **2007-07-20** Tillämpningsdatum:
Från och med detta datum ska den nationella lagstiftning som implementerar direktivet träda i kraft. Detta betyder att direktivets krav får tillämpas på nationell basis från och med detta datum.
- **2007-07-20 - 2009-07-20** Övergångsperiod:
Under denna tvåårsperiod får både det gamla och det nya direktivet tillämpas parallellt.
- **2009-07-20** Det gamla direktivet upphör att gälla.
EMC-direktiv (2004/108/EEG) gäller fullt ut.



Nya EMC direktivet 2004/108/EC

- Gäller för Utrustning (Apparat eller Fast installation)
- Märkning och dokumentation
Identifiering med typ-, tillverknings- / serienummer på varje apparat.
Varningstext på apparater som ej uppfyller emissionskraven i bostadsmiljö (class B)
Tillverkardeklaration med daterade referenser till EMC specifikationer.
- Harmoniserade standarder
Överensstämmelse med harmoniserad standard är inte tvingande, dvs det går att göra på annat sätt än vad som beskrivs i standarden.
- Competent Body blir Notified Body
Tillverkaren ansvarar för bedömningen. Frivilligt att använda en 3:e part (Notified body)
- Fast Installation
God branschpraxis skall dokumenteras och den eller de ansvariga personerna skall hålla dokumentationen tillgänglig för kontroll.

The European Commission has released a new "Quickguide" regarding the Directive 2004/108/EC
http://ec.europa.eu/enterprise/electr_equipment/emc/guides/emc_quickguide_en.pdf

Länkar finns på DELTA www.delta.dk



Typer av standarder

- **Basic standard**

Tar utgångspunkt i fenomenet och beskriver testmetoden.

ex. IEC 61000-4-2 Electrostatic discharge immunity test, CISPR 16-2 ...

- **Produkt standard** (harmoniserad EMC direktivet)

Tar utgångspunkt i produkt / produktfamilj

ex. EN 55022 Information technology equipment - Radio disturbance characteristics - Limits and methods of measurement

- **Generisk standard** (harmoniserad EMC direktivet)

Tar utgångspunkt i miljön.

ex. EN 61000-6-1 Immunity for residential, commercial and light-industrial environments



Europa - Harmoniserad standard

- Publicerad i Official Journal OJ

Lista över standards under respektive direktiv

<http://europa.eu.int/comm/enterprise/newapproach/standardization/harmstds>

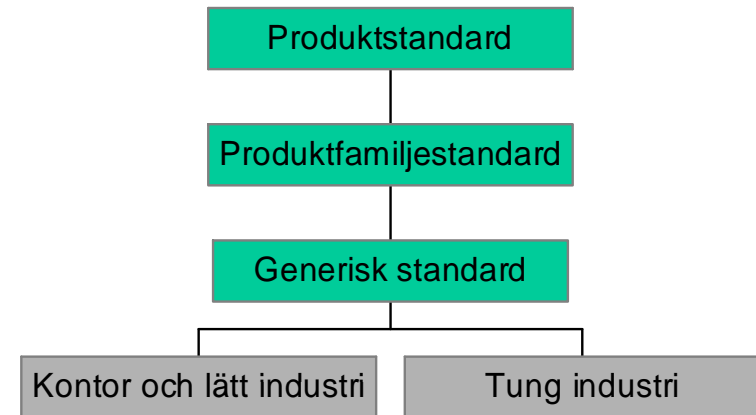

Summary list of titles and references of harmonised standards relating to EMC

This list replaces all the previous lists published in the Official Journal of the European Union. The Commission ensures the updating of this list. However, this list does not have any legal validity; only publication in the Official Journal produces legal affect.

European Standardisation Organisation	Reference and title of the standard (and reference document)	Reference of the superseded standard	Date of cessation of presumption of conformity of the superseded standard Note 1
CENELEC	EN 55022:1998 Information technology equipment - Radio disturbance characteristics - Limits and methods of measurement	EN 55022:1994 + A1:1995 + A2:1997	Date expired (01.10.2011)
CENELEC	EN 55022:2006 Information technology equipment - Radio disturbance characteristics - Limits and methods of measurement (CISPR 22:2005 (Modified)) Amendment A1:2007 to EN 55022:2006 (CISPR 22:2005/A1:2005)	EN 55022:1998 and its amendments Note 2.1 Note 3	01.10.2009 01.10.2010



Emissionskrav över 1 GHz

FCC kräver sedan länge mätning till max 40 GHz

Krav kommer nu i fler och fler standarder.

IT produkter EN 55022

Generisk std. EN 61000-6-3, -4

Multimedia CISPR 32

Marin IACS E10

1 GHz if internal source <108 MHz,

2 GHz if internal source 108 - 500 MHz

5 GHz if internal source 500 - 1000 MHz,

5 x source (max 6 GHz) if internal source >1 GHz

Validering av mätthall 1 – 18 GHz enligt CISPR 16-1-4 VSWR (voltage standing-wave ratio) (< 1 GHz NSA) kräver absorbenter på golvet mellan EUT och antenn.

DELTA's Hall A uppgraderad och uppmätt aug. 2009. Få lab. i Europa klara.



Site Validation VSWR 1 – 18 GHz

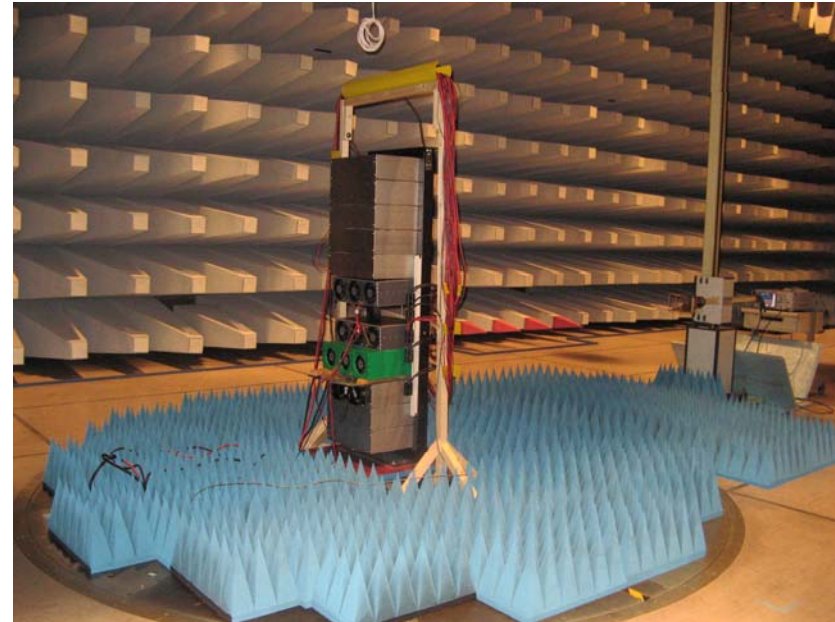
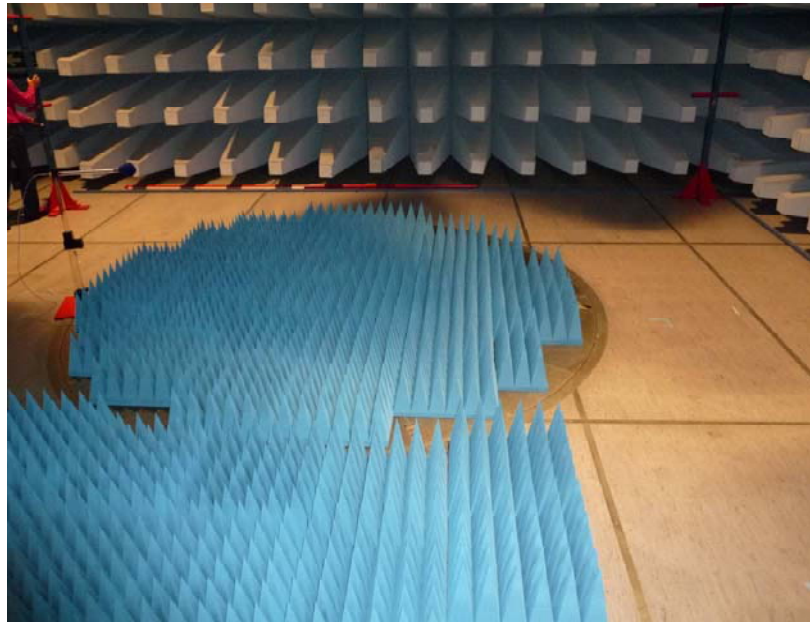
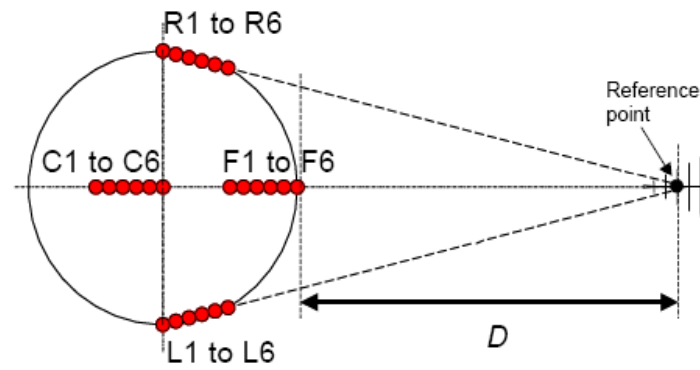

Alternativa mätmetoder

Alternativa mätmetoder kommer i flera standarder.

Radiated emission

- **OATS / SAC** *10m or 3 m for "small equipment" 1,2 m inkl. kablar*
- **FAR** *only tabel top equipment*
- **TEM Cell** *only battery powered equipment without cables*



Radiated immunity

- **SAC/FAR**
- **TEM Cell**
- **Modväxlande kammare**



Alternativa mätmetoder

“If more than one adequate test method exists for a characteristic, only one shall in principle be the subject of a document. If, for any reason, more than one test method is to be standardized, the referee (often called “reference”) method shall be identified in the document to resolve doubts or dispute.”

Nytt tolkningsförslag:

Referensmetoden är den metod som kunden väljer.

Intensiv debatt, mycket motstånd främst från Tyskland, Italien och myndigheter mm.



Generisk standard, Emission

EN 61000-6-3 : 2007

Emission kontor och hemmiljö

EN 61000-6-4 : 2007

Emission industrimiljö

Ny A1 (CISPR/H/188, 189/CDV)

- Emissionskrav 1-6 GHz
- Alternativa metoder för Radiated emission
- Röstningsdatum 2009-12-18



EN 55022 / CISPR 22 (Information Technology Equipment)

Ny A1: 2007 med emissionskrav upp till 6 GHz

1 GHz if internal source <108 MHz,

2 GHz if internal source 108 - 500 MHz

5 GHz if internal source 500 - 1000 MHz,

5 x source (max 6 GHz) if internal source >1 GHz

Validering av mäthall 1 – 18 GHz enligt CISPR 16-1-4 VSWR (> 1 GHz NSA) kräver absorbenter på golvet mellan EUT och antenn.

DELTA's Hall A uppgraderad och uppmätt aug. 2009. Få lab. i Europa klara.

dow 2010-10 (framflyttad till 2011 pga PLT)

Emission på LAN/Telekom. portar krav sedan tidigare.



CISPR 16

CISPR 16-1, CISPR 16-2, CISPR 16-3 and CISPR 16-4 have been reorganised into 14 parts, to accommodate growth and easier maintenance. The new parts have also been renumbered. See the list given below.

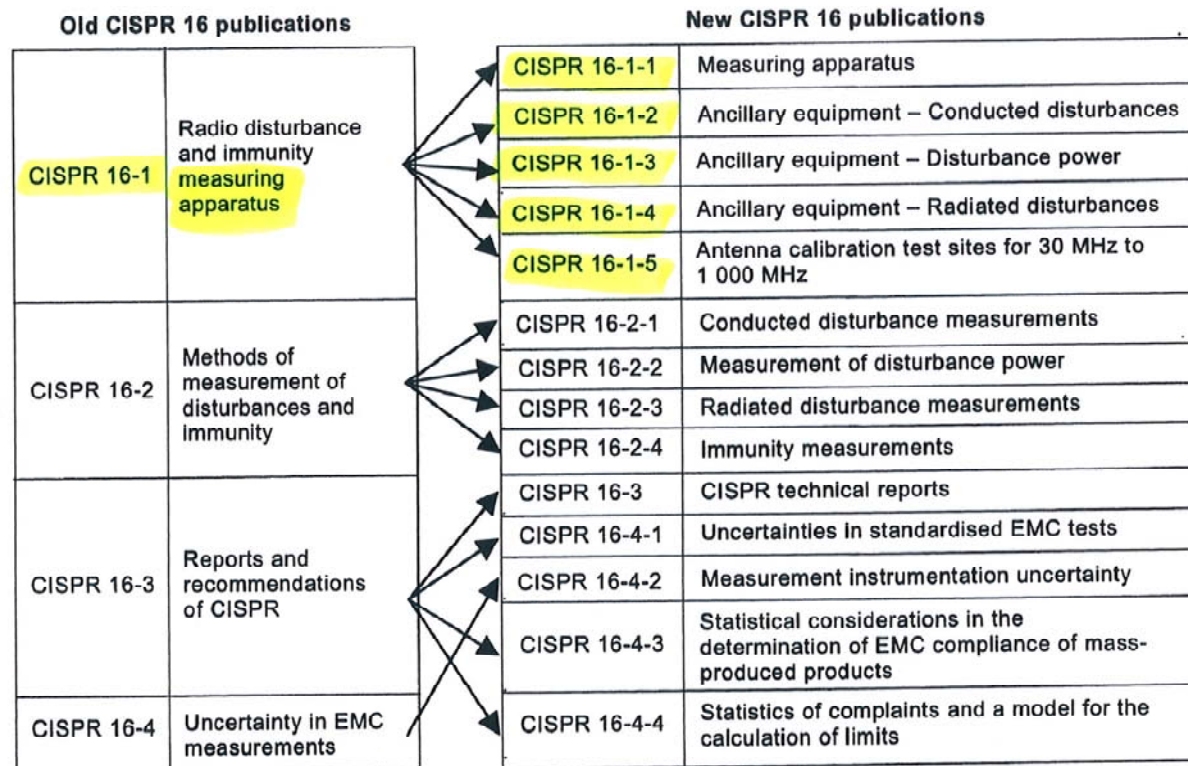

Multimedia Equipment

Information technology equipment, multimedia equipment and receivers as well as audio and visual equipment.

- **CISPR 32 Emission**
ersätter CISPR 13 och 22
- **CISPR 35 Immunity**
ersätter CISPR 20 och 24

The scope of this standard does not list specific equipment deliberately, however examples of multimedia equipment include:

Radio and television receivers, audio amplifiers, DVD players
Portable entertainment devices, for example CD players
Computers and peripheral equipment
Routers, hubs and switches
Telecommunication equipment
Gaming machines
Audio/Video equipment intended to be mounted in Vehicles
Electronic musical instruments
etc....



Standard uppdatering

- **EN 55014-1 Household appliances, electric tools and similar app.- Emission**

Sliding absorbing clamp in the frequency range 30 - 300 MHz

New Radiated emission 30 – 1000 MHz

- **EN 60601-1-2 Medical electrical equipment**

NP förslag med stora förändringar, bl.a. uppdelning i användarmiljö – Sjukhus –Kliniker –Hem – Fordon

- **Kommande standard för Aftermarket equipment in vehicles**

Endast en typ av objekt, Radiated immunity borttaget



EMC Seminarium 14 nov.

08.30 Registrering och fika

09.00 Välkomna till seminariet

- 09.05 Nyheter om EMC direktivet och standarder (Ulf Bjerke)

- **09.30 Focus on EMC in safety related products (Kristian B. Voetmann)**

10.35 Paus med Fika

- 10.45 Säkerhetsaspekter i en trådlös produkt (Fredrik Thorsell)
- 11.00 Säker EMC design (Ulf Bjurman)
- 11.30 EMC demo: Praktiska PCB råd (Fredrik Thorsell)

12.00 Lunch

- 13.00 Würth 1 (Lorandt Fölkel)

14.30 Paus

- 14.45 Würth 2 (Lorandt Fölkel)

16.00 Avslutning



We help ideas meet the real world



Multimedia Equipment



CISPR/I/295/CD

COMMITTEE DRAFT (CD)

IEC/TC or SC: CISPR/I	Project number CISPR 32	
Title of TC/SC: Electromagnetic compatibility of information technology equipment, multimedia equipment and receivers	Date of circulation 2009-03-20	Closing date for comments 2009-06-26
Also of interest to the following committees	Supersedes document CISPR/I/250/NP, CISPR/I/259/RVN	
Proposed horizontal standard <input type="checkbox"/> Other TC/SCs are requested to indicate their interest, if any, in this CD to the TC/SC secretary		
Functions concerned: <input type="checkbox"/> Safety <input checked="" type="checkbox"/> EMC <input type="checkbox"/> Environment <input type="checkbox"/> Quality assurance		
Secretary: Takashi YAMAGUCHI - Japan	THIS DOCUMENT IS STILL UNDER STUDY AND SUBJECT TO CHANGE. IT SHOULD NOT BE USED FOR REFERENCE PURPOSES. RECIPIENTS OF THIS DOCUMENT ARE INVITED TO SUBMIT, WITH THEIR COMMENTS, NOTIFICATION OF ANY RELEVANT PATENT RIGHTS OF WHICH THEY ARE AWARE AND TO PROVIDE SUPPORTING DOCUMENTATION.	

Title:
CISPR 32 Ed.1: Electromagnetic compatibility of multimedia equipment - Emission requirements



Standardisering

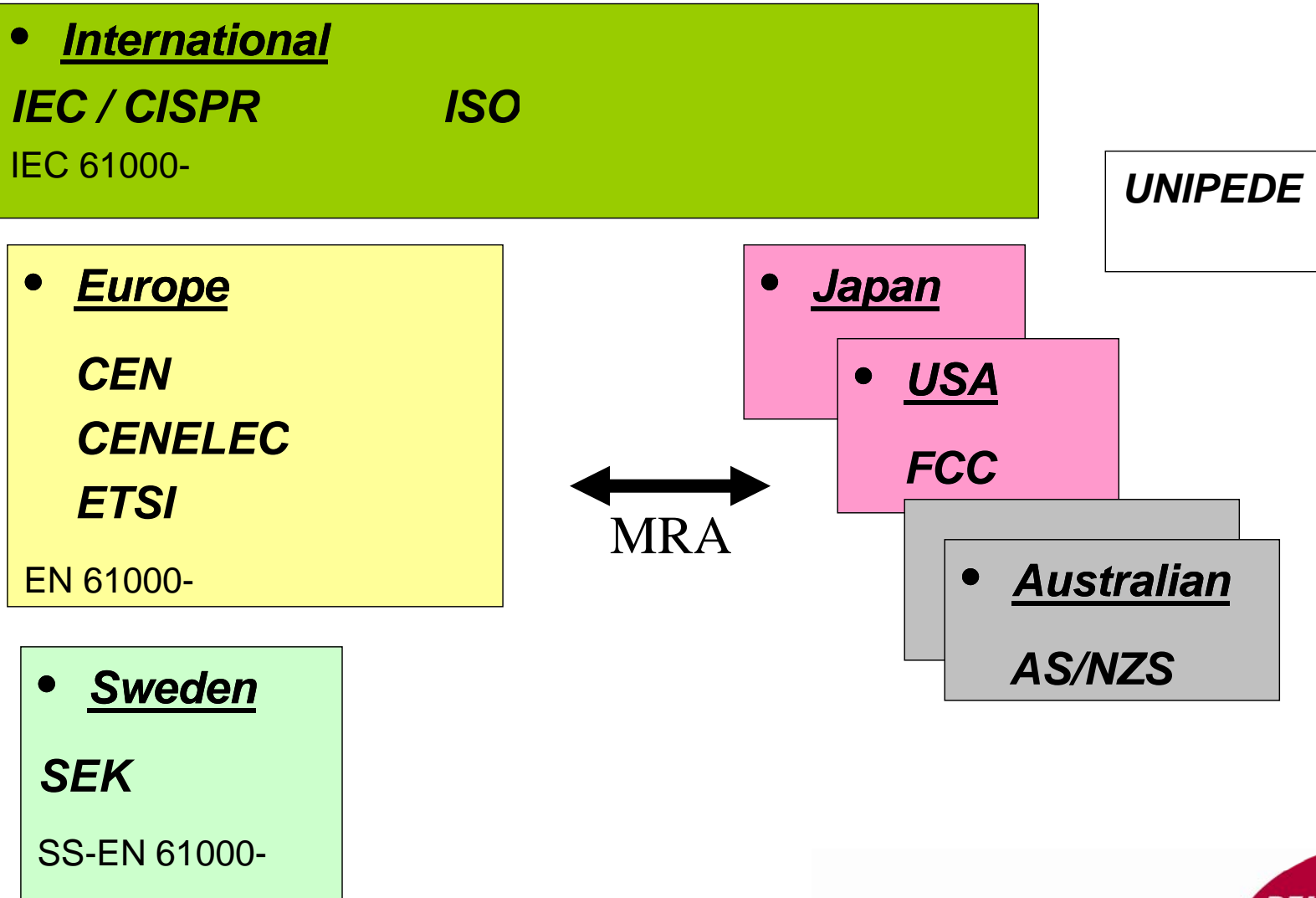

Standardisering i Europa

CEN

European Committee for Standardization

<http://www.cenorm.be/>

CENELEC

European Committee for Electrotechnical
Standardization

<http://www.cenelec.org/>

ETSI

European Telecommunications
Standards Institute

<http://www.etsi.org/>



Standardisation

Table 1 — Project stages and associated documents

Project stage	Associated document	
	Name	Abbreviation
Preliminary stage	Preliminary work item	PWI
Proposal stage	New work item proposal	NP
Preparatory stage	Working draft(s) ¹⁾	WD
Committee stage	Committee draft(s) ¹⁾	CD
Enquiry stage	Enquiry draft ²⁾	ISO/DIS IEC/CDV
Approval stage	final draft International Standard ³⁾	FDIS
Publication stage	International Standard	ISO, IEC or ISO/IEC

1) These stages may be omitted, as described in Annex F.
 2) Draft International Standard in ISO, committee draft for vote in IEC.
 3) May be omitted (see 2.6.4).



Standardisation

- *NP new proposal*
- *CD committee draft*
- *CDV committee draft for voting*
- *DIS draft International Standard*
- *FDIS final draft international standard*

Time from NP to International standard is max 60 months.

Time from CDV to FDIS is 6 months

Time from FDIS to International standard is 2 months

